

Technical Data Sheet 2023

10K Ortho Model Resin(IPA Clean)

10K Water washable Ortho Model Resin

Pro Model Resin

D-CAST Resin

Surgical Guide Resin

Gingiva Mask Resin

C&B Resin

Tray Resin

Printing Setting

Model No.	Layer height (mm)	Bottom exposure time(s)	Layer exposure time(s)	Bottom Lift Distance (mm)	Lifting Distance (mm)	Bottom Lift Speed (mm/min)	Lifting Speed (mm/min)	Retract Speed (mm/min)	Rest time after retract
10K Ortho model resin	0.05	25-35s	2.5-3.5s	6	6	60	80	150	2--3
10K Water Washable Ortho Model Resin									
Pro model resin		20-30s	2.5-4.5s						
Surgical guide resin			4-6s						
Gingiva mask resin			4-8s						
C&B resin			3-6s						
Tray resin		30-50s	3-5s						
D-CAST resin									

Above settings are tested on ELEGOO MARS 3 (6.6" monochrome LCD screen, light intensity 3500~4500 $\mu\text{w}/\text{cm}^2$), they can be adjusted according to different 3d printers and printed model structure, other settings keep as default firstly.

- Bottom layer count = Bottom layer thickness/ Layer height+1, e.g. Bottom height 0.4mm, layer height 50um, the bottom layer count= 0.4mm/0.05mm+1=9 layers.
- The exposure time should be adjusted according to printer light energy, layer thickness and model structure. If the layer height less than 50um, we suggest the exposure time of each layer will be deducted about 0.5s.
- If light power of printer is getting weak and cause failure, don't forget to add exposure time.
- When printing with ordinary FEP/NFEP film, the recommended lifting distance as below:
 Less than 7" screen size, lifting distance: 6mm
 7-10" screen size, lifting distance: 8-10mm
 10.1" screen size, lifting distance: 11mm
 13.3" screen size, lifting distance: 14mm
 15" screen size, lifting distance: 15mm
 Lifting distance can be decrease 30-50% if you are using ACF film.

Notice:

- Shake the resin well before use.
- Please increase lifting distance 20-30% when print with Gingiva Mask Resin .

Technical Specification

10K Ortho Model Resin & Pro Model Resin & D-CAST Resin & Surgical Guide Resin

	10K Ortho Model resin	Pro Model Resin	D-CAST Resin	Surgical Guide Resin	Test Standard
Tensile strength (MPa):	37.88 ±10%	25.9 ±10%	133.97 ±10%	25.62 ±10%	ASTM D638
Tensile modulus (MPa):	615.49 ±10%	305.9 ±10%	433.67 ±10%	320.8 ±10%	ASTM D638
Elongation at yield point(%):	3.09 ±10%	5.61 ±10%	6.22 ±10%	5.5 ±10%	ASTM D638
Flexural modulus (MPa):	1699.7 ±10%	616.4 ±10%	811.08 ±10%	693.51 ±10%	ASTM D790
Flexural strength (MPa):	57.91 ±10%	22.2 ±10%	39.81 ±10%	41.4 ±10%	ASTM D790
Notched impact strength (J/m):	72 ±10%	192.6 ±10%	113.97 ±10%	118.46 ±10%	ASTM D256
Maximum pulling force (N):	1575.9 ±10%	1077.8±10%	1272.9 ±10%	1576.9 ±10%	ASTM D638
Maximum force point of deformation (mm)	3.62 ±10%	14.47 ±10%	5.04 ±10%	9.99 ±10%	ASTM D638
Elongation at break (%):	6.41 ±10%	25.5 ±10%	8.85 ±10%	17.65 ±10%	ASTM D638
Hardness (Shore D):	80-88 D	80-85 D	85-88 D	80-85 D	ASTM D2240
Viscosity (MPa.S):	250-400	250-450	50-170	250-450	GB/T 4472
Density (g/cm³):	1.05-1.25	1.05-1.25	1.05-1.25	1.05-1.25	GB/T 22235

Gingiva Mask Resin & C&B Resin & Tray Resin

	Gingiva Mask Resin	C&B Resin	Tray Resin	10K Water Washable Ortho model Resin	Test Standard
Tensile strength (MPa):	1.33 ±10%	30.00 ±10%	25.62 ±10%	31.44 ±10%	ASTM D638
Tensile modulus (MPa):	1.32 ±10%	490.91 ±10%	320.8 ±10%	471.03 ±10%	ASTM D638
Elongation at yield point(%):	40.62 ±10%	6.36 ±10%	5.5 ±10%	6.32 ±10%	ASTM D638
Flexural modulus (MPa):	--	927.13 ±10%	693.51 ±10%	1091.45 ±10%	ASTM D790
Flexural strength (MPa):	--	30.98 ±10%	25.48 ±10%	40.82±10%	ASTM D790
Notched impact strength (J/m):	--	32 ±10%	118.46±10%	50±10%	ASTM D256
Maximum pulling force (N):	55.3 ±10%	1248.4 ±10%	1065.9 ±10%	1014.9 ±10%	ASTM D638
Maximum force point of deformation (mm)	40.62 ±10%	3.56 ±10%	9.99 ±10%	4.33 ±10%	ASTM D638
Elongation at break (%):	110.28 ±10%	32 ±10%	17.65 ±10%	7.65 ±10%	ASTM D638
Hardness (Shore D):	50-60 D	80-90 D	80-85 D	80-85 D	ASTM D2240
Viscosity (MPa.S):	350-550 D	100-250	250-450	70-175	GB/T 4472
Density (g/cm³):	1.05-1.25	1.05-1.25	1.05-1.25	1.05-1.25	GB/T 22235

Introduction of Testing Machine & Testing Environment

Computer-controlled Servo Tensile Testing Machine

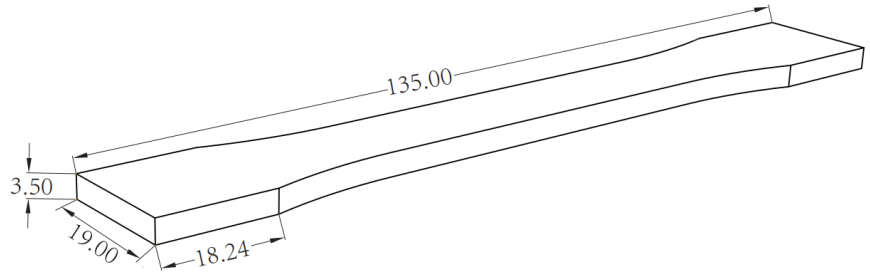
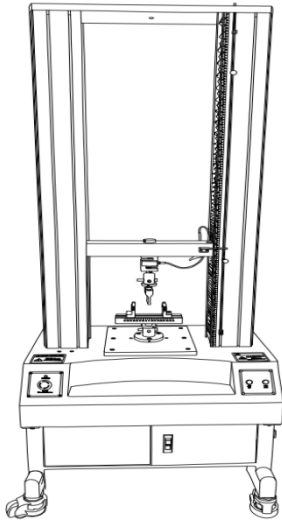

Tensile test specimen ASTM D638

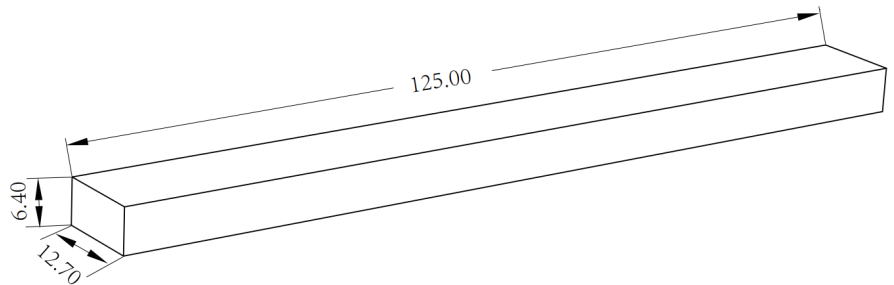

Flexural test specimen ASTM D790

Digital IZOD Impact Tester

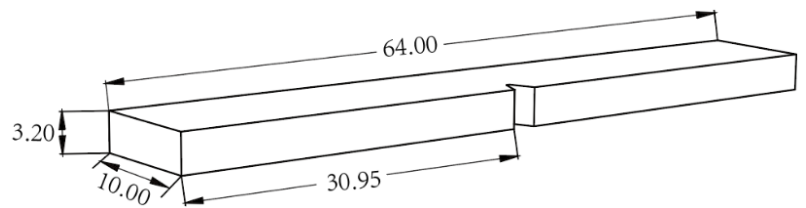
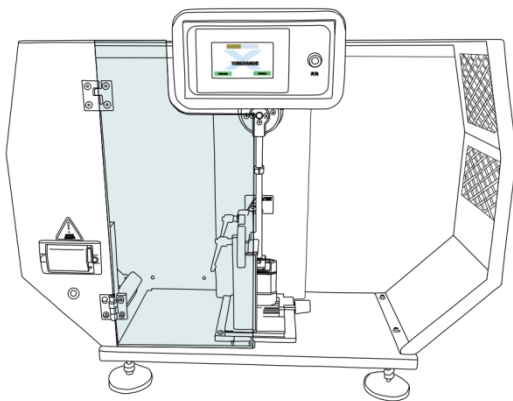

Impact test specimen ASTM D256

Testing Environment

Temperature: $23 \pm 2^{\circ}\text{C}$

Relative Humidity: $50\%RH \pm 5\%RH$

Standard For Testing Splines: ASTM

Post Curing Box: 405nm UV, 200mw/cm²

Put the test strip in water and post cured for 1 minute on both sides.

Cleaning and Post-curing



1. Take off the printing platform from the printer.

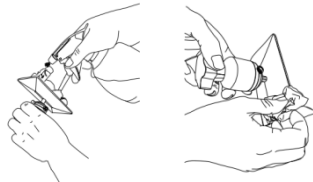

2. Spray isopropanol (alcohol >95%) to clean away residue resin on the prints wipe off the resin with tissue on the platform.

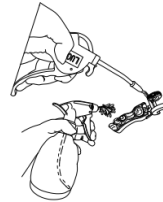

3. Spray alcohol again then dry it repeat a few times till no resin on surface.



4. Carefully take off the prints from platform with scraper.

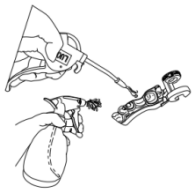

5. Repeat step 3.



6. Place the work piece into a container with alcohol, the alcohol should fully cover it.

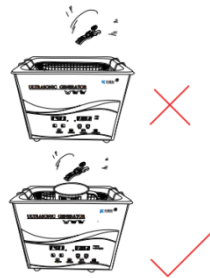

7. Put the container into ultrasonic machine, clean for 1-2 mins.

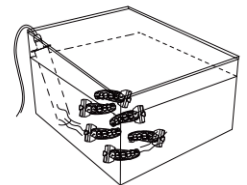

8. If no ultrasonic cleaner, try to use an ultrasonic rod, Clean for 5-10mins.

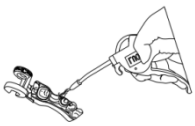

9. Take out the prints and dry immediately with an air gun or blower.

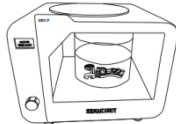

10. Suggest to do post curing in water, curing time depends on the light power of the curing box, (Curing time 30-60s, curing both sides). Repeat step 9.

Notice: For water washable resin, just cleaning with water by ultrasonic machine, don't forget to dry them in and out after post curing.

Caution

1. Wash hand and face thoroughly after handling.
2. Wear protective gloves / mask/protective clothing when using resin.
3. Contact eyes may cause irritation, immediately flush eyes with plenty of water for at least 15 minutes. Seek medical advice immediately if necessary.
4. Waste water/waste shall be disposed of in accordance with local environmental regulations.

Storage

1. Please seal the product and store it in a dry, well-ventilated room with no corrosive gas.
2. Stored at 25~30°C environment.
3. Keep away from heat source, keep away from moisture and avoid sun exposure.
4. Shelf life 18 months.